

740 C - 741 C

EN

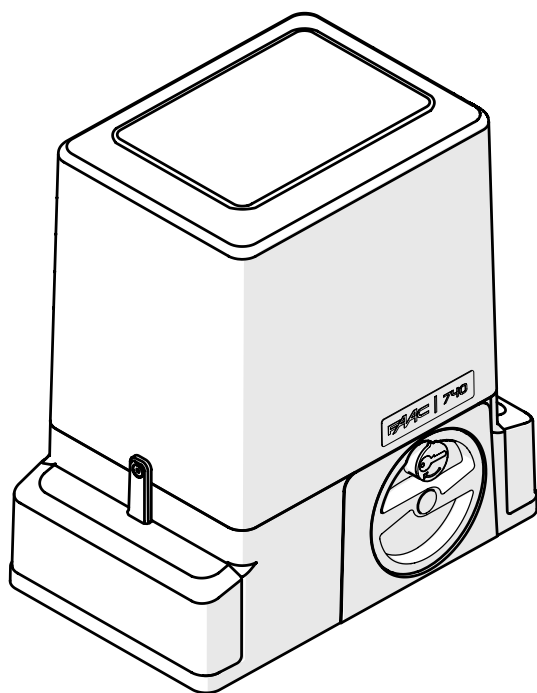

FAAC



FAAC S.p.A. Soc. Unipersonale
Via Calari, 10 - 40069 Zola Predosa BOLOGNA - ITALY
Tel. +39 051 61724
www.faac.it - www.faactechnologies.com

EN

Translation of the original instructions

© Copyright FAAC S.p.A. from 2025. All rights reserved.

No part of this manual may be reproduced, archived, distributed to third parties nor copied in any other way, in any format and with any means, be it electronic, mechanical or by photocopying, without prior written authorisation by FAAC S.p.A.

All names and trademarks mentioned are the property of their respective manufacturers.



Customers may make copies exclusively for their own use.

This manual was published in 2025.

CONTENTS

1. INTRODUCTION TO THE INSTRUCTION MANUAL	2
Safety warnings for the installer	2
Online instructions	2
Meaning of the symbols used	2
2. 740 C - 741 C	3
2.1 Unpacking and handling	3
Checking the goods supplied	3
2.2 Product identification	4
Markings on the product	4
2.3 Intended use	5
2.4 Limitations of use	5
2.5 Unauthorised use	6
2.6 Emergency use	7
2.7 Manual operation	7
Releasing the gearmotor	7
Restoring operation	7
2.8 Technical specifications 740 C - 741 C	8
Technical data	9
2.9 Component identification	10
Components supplied	10
Components supplied separately	11
2.10 Dimensions	11
2.11 Example system	12
2.12 Installation dimensions	13
3. MECHANICAL INSTALLATION	14
Tools required	14
3.1 Installing the foundation plate	14
3.2 Installing the gearmotor	15
3.3 Installing the rack	16
Steel rack - Weld-on fastenings	16
Steel rack - Screw-on fastenings	17
Nylon rack	18
3.4 Adjusting and fastening permanently	19
4. ELECTRONIC INSTALLATION	20
4.1 Position the board unit horizontally	20
4.2 Connecting and starting the electronic board	20
4.3 Installing the limit switches	21
5. PUTTING INTO SERVICE	23
5.1 Final operations	23
Reposition the board unit vertically	24
Replace the cover and the guards	24
6. MAINTENANCE	25
6.1 Scheduled maintenance	25
7. INSTRUCTIONS FOR USE	27
7.1 Emergency use	27
7.2 Manual operation	27
Releasing the gearmotor	27
Restoring operation	27

TABLES

 1	Technical data for 740 C and 740 C 115V	9
 2	Technical data for 741 C and 741 C 115V	9
 3	Scheduled maintenance	25

APPENDICES

 1	Foundation for leaves of maximum weight and width ..	28
---	--	----

1. INTRODUCTION TO THE INSTRUCTION MANUAL

This manual provides the correct procedures and requirements for installing 740 C - 741 C and maintaining it in a safe condition.

In Europe, the automation of a gate falls under the Machinery Directive 2006/42/EC and the corresponding harmonised standards. Anyone automating a gate (new or existing) is classified as the Manufacturer of the Machine. They are therefore required by law, among other things, to carry out a risk analysis of the machine (automatic gate in its entirety) and take protective measures to fulfil the essential safety requirements specified in Annex I of the Machinery Directive.

FAAC S.p.A. recommends that you always comply with the EN 12453 standard and in particular that you adopt the safety criteria and devices indicated, without exception, including the dead-man function.

This manual contains references to European standards. The automation of a gate must fully comply with any laws, standards and regulations applicable in the country where installation will take place.

 Unless otherwise specified, the measurements provided in the instructions are in mm.

SAFETY WARNINGS FOR THE INSTALLER

Before starting the installation, read and follow the "Safety instructions for the installer" booklet supplied with the gearmotor and these installation instructions.

ONLINE INSTRUCTIONS

When you receive your goods, to go directly to the specific instructions page for the product, scan the QR code associated with the ISO 70000 - 0790 icon on the product.

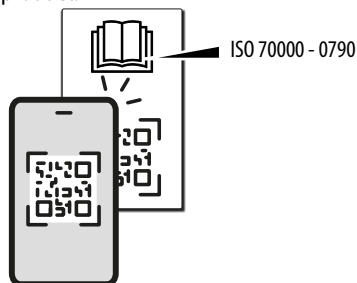

MEANING OF THE SYMBOLS USED

NOTES AND WARNINGS ON THE INSTRUCTIONS



WARNING, risk of personal injury hazard or damage to components - Perform the operation or steps in accordance with the instructions and safety warnings provided.



WARNING - Details and specifications which must be respected in order to ensure that the system operates correctly.



Presence of a magnetic field.



Danger to wearers of implantable medical devices. Keep 30 cm (12 in) away from the magnetic field.



RECYCLING AND DISPOSAL - The materials used in manufacturing, the batteries and any electronic components must not be sent to landfill. They must be taken to authorised recycling and disposal centres.





FIGURE E.g.:  1-3 see Figure 1 - item 3.



TABLE E.g.:  1 see Table 1.



CHAPTER/SECTION E.g. § 1.1 see section 1.1.

2. 740 C - 741 C

2.1 UNPACKING AND HANDLING

Open the package and remove the contents.

To lift the gearmotor, grip the body firmly with both hands, DO NOT grip the plastic parts or the electronic board.

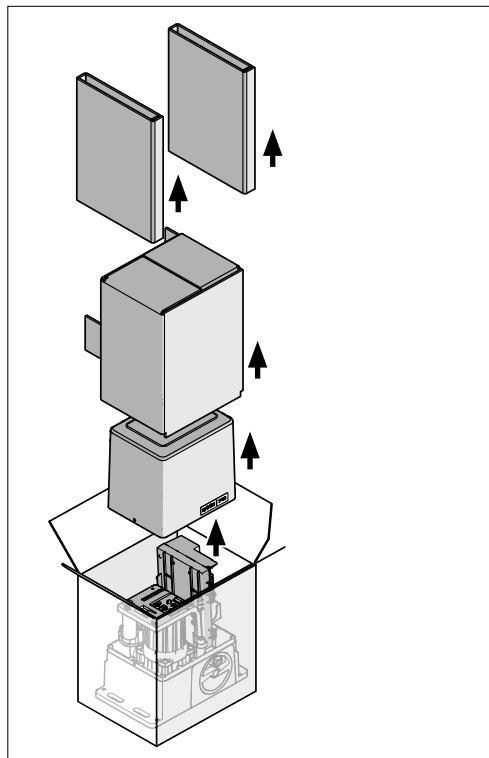

CHECKING THE GOODS SUPPLIED

Check that all components are present and intact.

- 1 Cover
- 2 Gearmotor
- 3 Foundation plate
- 4 Brackets with nuts and washers
- 5 Bracket guards
- 6 Hardware/accessories
- 7 Magnetic limit switch
- 8 Printed documentation

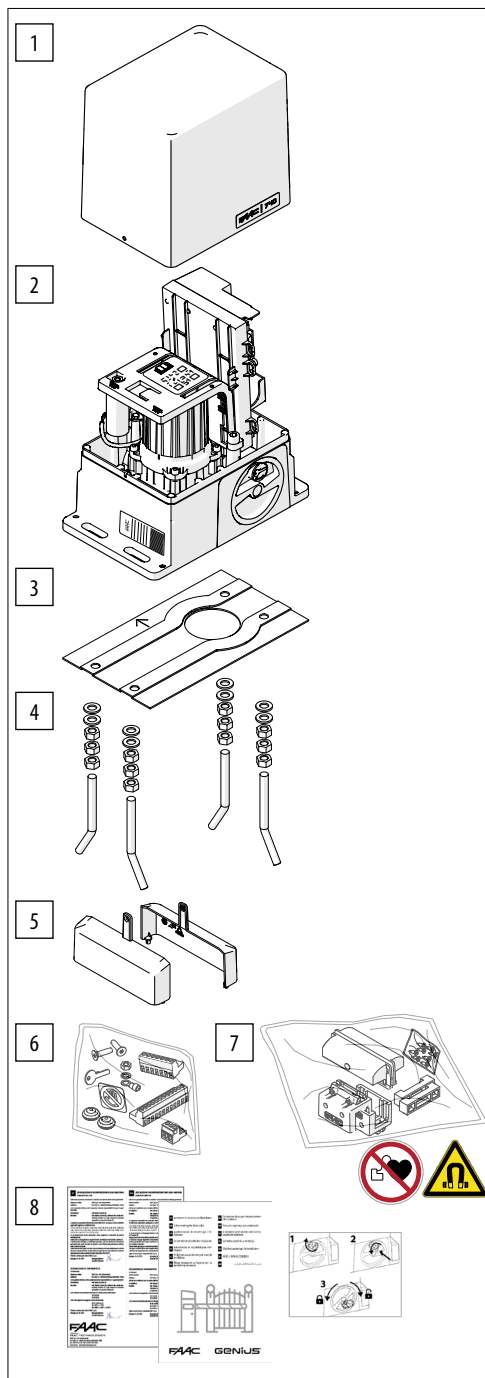

2.2 PRODUCT IDENTIFICATION

The gearmotor's nameplate and identification data is shown on the label:

- A** Product name
- B** Product code
Example: 123456
- C** Month and year of production
Example: 0125 (January 2025)
- D** Progressive number of the month and year of production
Example: 0001
- E** Identification number (B+C+D)
Example: 123456 0000 0125 0001

MARKINGS ON THE PRODUCT

- 1 Sticker that indicates the risk of trapping fingers / hands due to the rotation of the pinion. It must be placed on the cover by the installer.
- 2 Adhesive sign on the product. Contains the QR code for direct access to the online manual.

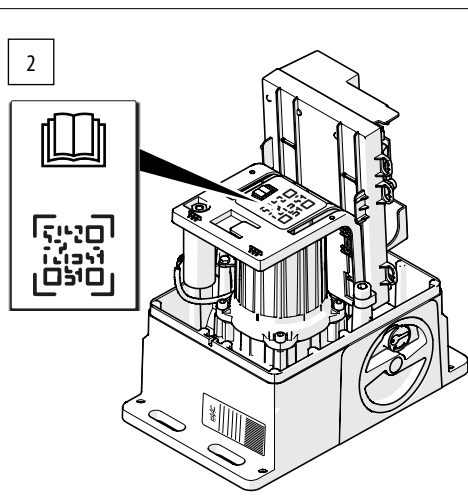
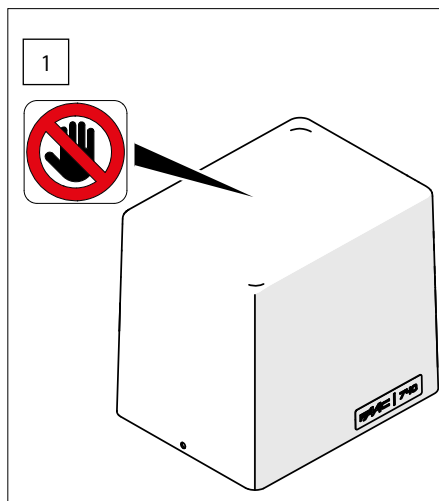
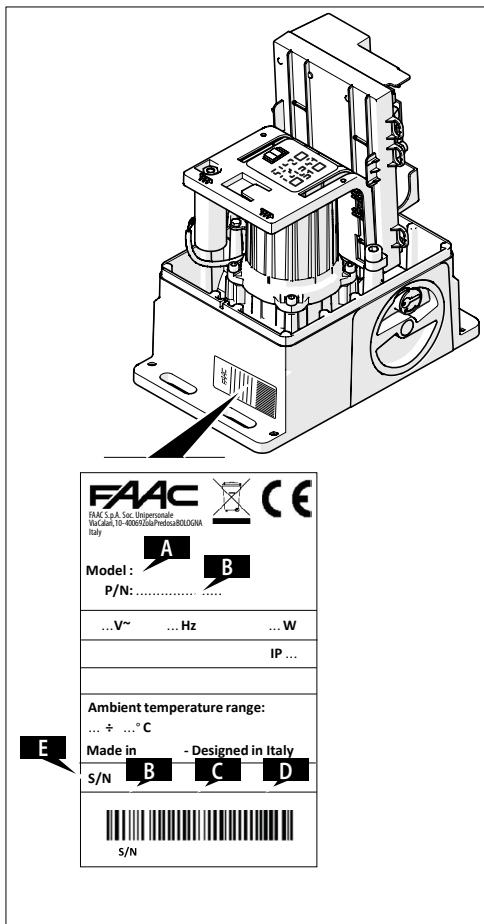

2.3 INTENDED USE

FAAC series 740 C - 741 C gearmotors have been designed to control motorized horizontal movement sliding gates intended for installation in areas that are accessible to people, the main purpose of which is to provide safe access for goods, vehicles and people to industrial, commercial or residential buildings.

Only one gearmotor must be installed for each leaf. The system requires a special foundation plate embedded in a plinth. The gate must be moved via a drive pinion and a rack (supplied separately).

To move the gate manually, follow the instructions in section § Manual operation.

Any other use that is not expressly specified in these instructions is prohibited and could affect the integrity of the product and/or represent a source of danger.

2.4 LIMITATIONS OF USE

The maximum force required to move the leaf by hand over its entire length of travel must be 225 N for residential areas and 260 N for industrial or commercial areas.

The maximum force required to start the movement must be less than the maximum torque at initial thrust of the operator indicated in the technical data.

The leaf must fall within the dimensional and weight limits indicated in the technical data.

The presence of weather conditions such as snow, ice and strong wind, even occasional, could affect the correct operation of the automation, the integrity of the components and be a potential source of danger (see § Emergency use).

740 C - 741 C is not designed to be a security (break-in protection) system.

If there is a pedestrian access gate integrated in the leaf of the gate, the motorised movement must be disabled when the pedestrian gate is not in a safe position.

The installation must be visible during the day and at night. If it is not, appropriate solutions must be provided to make the fixed and moving parts visible.

Implementing the automation requires the installation of the necessary safety devices, identified by the installer through an appropriate risk assessment of the installation site.

2.5 UNAUTHORISED USE

- Uses other than the intended use are prohibited.
- It is prohibited to install the automation system outside of the limits specified in the Technical Data and in the Mechanical and Electrical Installation Requirements.
- It is forbidden to use 740 C - 741 C in a constructional configuration other than the one provided by the manufacturer.
- No component part of the product may be modified.
- It is prohibited to install the automation system on escape routes.
- It is prohibited to install the automation system to create fire doors.
- It is prohibited to install the automation system in environments in which there is a risk of explosion and/or fire: the presence of flammable gases or fumes is a serious safety hazard (the product is not ATEX certified).
- It is prohibited to power the system with energy sources other than those specified.
- It is prohibited to integrate commercial systems and/or equipment other than those specified, or use them for purposes not intended and authorised by their respective manufacturers.
- Do not allow water jets of any type or size to come into direct contact with the gear motor.
- Do not expose the gear motor to corrosive chemicals or atmospheric agents.
- It is prohibited to use and/or install accessories which have not been specifically approved by FAAC S.p.A.
- It is prohibited to use the automation system before performing commissioning.
- It is prohibited to use the automation system in the presence of faults which could compromise safety.
- It is prohibited to use the automation system with the fixed and/or mobile guards removed or altered.
- Do not use the automation system unless the area of operation is free of persons, animals or objects.
- Do not enter/remain in the area of operation of the automation system while it is moving.
- Do not try to prevent the movement of the automation system.
- Do not climb on, hold onto or let yourself be pulled by the leaf. Do not climb onto the gear motor.
- Do not allow children to approach or play in the area of operation of the automation system.
- Do not allow the control devices to be used by anyone who is not specifically authorised and trained to do so.
- Do not allow the control devices to be used by children or persons with mental and physical deficiencies unless they are supervised by an adult who is responsible for their safety.
- During manual operation, gently guide the leaf the whole way, do not push it and let it slide freely.

2.6 EMERGENCY USE

In emergencies or if there is a fault, turn off the power supply to the automation. If the leaf can be moved safely by hand, use the **MANUAL OPERATION** mode; otherwise place the automation out of service until it has been reset/repaired.

In the case of a breakdown, the automation must be reset/repaired exclusively by the installer/maintenance technician.

2.7 MANUAL OPERATION

In order to move the leaf manually, the gearmotor has to be released using the knob with key.

RELEASING THE GEARMOTOR

1. Rotate the lock cover.
2. Insert the key and turn it clockwise by 90°.
3. Turn the release knob clockwise until it stops.

RESTORING OPERATION

4. Turn the release knob anticlockwise until it stops.



Move the leaf manually to make sure that the mechanical system meshes correctly.

When finished, remove the key and reposition the lock cover.

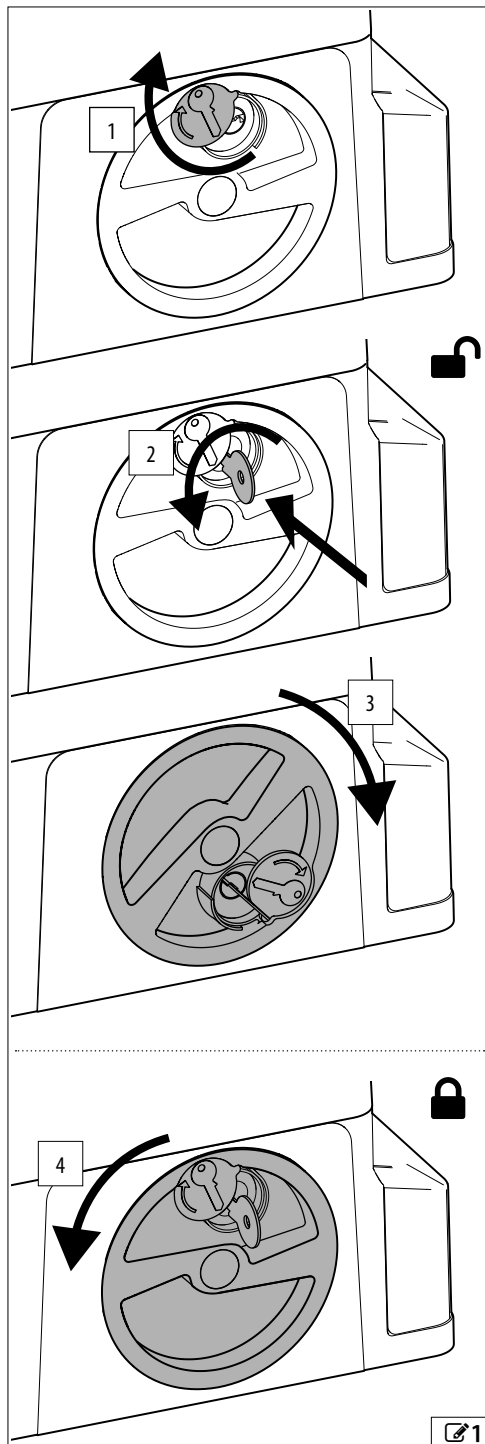

2.8 TECHNICAL SPECIFICATIONS 740 C - 741 C

The product is an electromechanical gearmotor supplied with a built-in electronic board E781 S LC and a Z16 pinion for a module 4 rack (the rack is supplied separately).

■ **VERSIONS 740 C, 740 C 115V, 741 C, 741 C 115V**

The product versions differ according to the motor, capacitor and the 230 V/115 V supply voltage.

IRREVERSIBLE SYSTEM

In order to be operated manually, the gearmotor has to be released using the knob with key.

MAGNETIC OPENING/CLOSING LIMIT SWITCHES

The magnetic limit switches, to be mounted on the rack, are very reliable due to the absence of moving mechanical parts and micro switches.

FOUNDATION PLATE

The gearmotor must be mounted on a concrete plinth using the foundation plate and the anchors supplied.

MAGNETIC ENCODER

The high-resolution encoder is integrated in the gearmotor and allows the on board E781 S LC to determine the position of the leaf and the speed of movement.

ELECTRONIC BOARD E781 S LC

See the dedicated instructions:



<https://www.faac.help/products/e781/>

TECHNICAL DATA

1 Technical data for 740 C and 740 C 115V

(refer to 230 V~ @50 Hz/ 115 V~ @60 Hz)

	740 C	740 C 115 V
Power supply voltage	220 - 240 V~ @50/60 Hz	110 - 120 V~ @50/60 Hz
Max power	430 W	390 W
Pinion	Z16 Module 4	Z16 Module 4
Max torque at initial thrust	380 N	330 N
Max thrust force	450 N	350 N
Max leaf weight	500 kg	500 kg
Max leaf speed	12 m/min	14 m/min
Max leaf length	15 m	15 m
Stopping space	25 mm	25 mm
Type of use	Residential	Residential
Use frequency	56 cycles/h	25 cycles/h
for leaves up to 5 m wide and maximum weight		
Protection rating	IP44	IP44
Ambient operating temperature	-20°C - +55°C	-20°C - +55°C
Thrust capacitor	10 µF	30 µF
Thermal protection	140°C automatic rearming	140°C automatic rearming
Sound pressure (LpA)	≤ 70 dB(A)	≤ 70 dB(A)
Gearmotor weight	11.9 kg	12.3 kg

2 Technical data for 741 C and 741 C 115V

(refer to 230 V~ @50 Hz/ 115 V~ @60 Hz)

	741 C	741 C 115 V
Power supply voltage	220 - 240 V~ @50/60 Hz	110 - 120 V~ @50/60 Hz
Max power	530 W	790 W
Pinion	Z16 Module 4	Z16 Module 4
Max torque at initial thrust	570 N	520 N
Max thrust force	680 N	800 N
Max leaf weight	900 kg	900 kg
Max leaf speed	12 m/min	14 m/min
Max leaf length	15 m	15 m
Stopping space	25 mm	25 mm
Type of use	Residential	Residential
Use frequency	56 cycles/h	33 cycles/h
for leaves up to 5 m wide and maximum weight		
Protection rating	IP44	IP44
Ambient operating temperature	-20°C - +55°C	-20°C - +55°C
Thrust capacitor	12.5 µF	50 µF
Thermal protection	140°C automatic rearming	140°C automatic rearming
Sound pressure (LpA)	≤ 70 dB(A)	≤ 70 dB(A)
Gearmotor weight	13.1 kg	13.5 kg

2.9 COMPONENT IDENTIFICATION

COMPONENTS SUPPLIED

Gearmotor

- 1 Gearmotor body
- 2 Thrust capacitor
- 3 Slide for board
- 4 Encoder reading board
- 5 Cover
- 6 Electronic board E781 S LC with protective cover
- 7 Key release knob
- 8 Limit switch sensor
- 9 Pinion with hand guard
- 10 Earth connector
- 11 Foundation plate with fixings and mounting hardware

Hardware/accessories

- 12 Magnetic limit switches
- 13 Gearmotor bracket guards
- 14 Cover screws, terminal boards, cable lug for earth cable and adhesive hazard warning sign, release key, cable glands
- 15 Documentation supplied (partly hard copy, partly online)
- 16 Sticker indicating the direction of rotation of the release knob

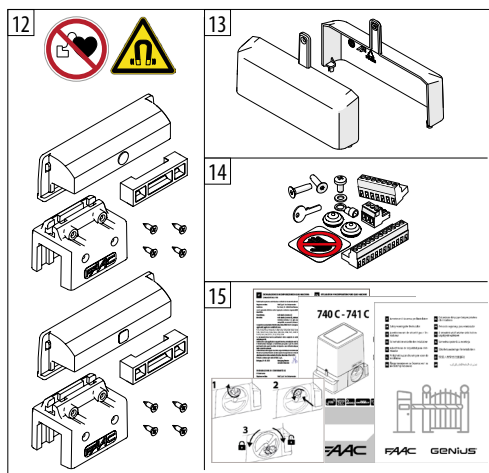
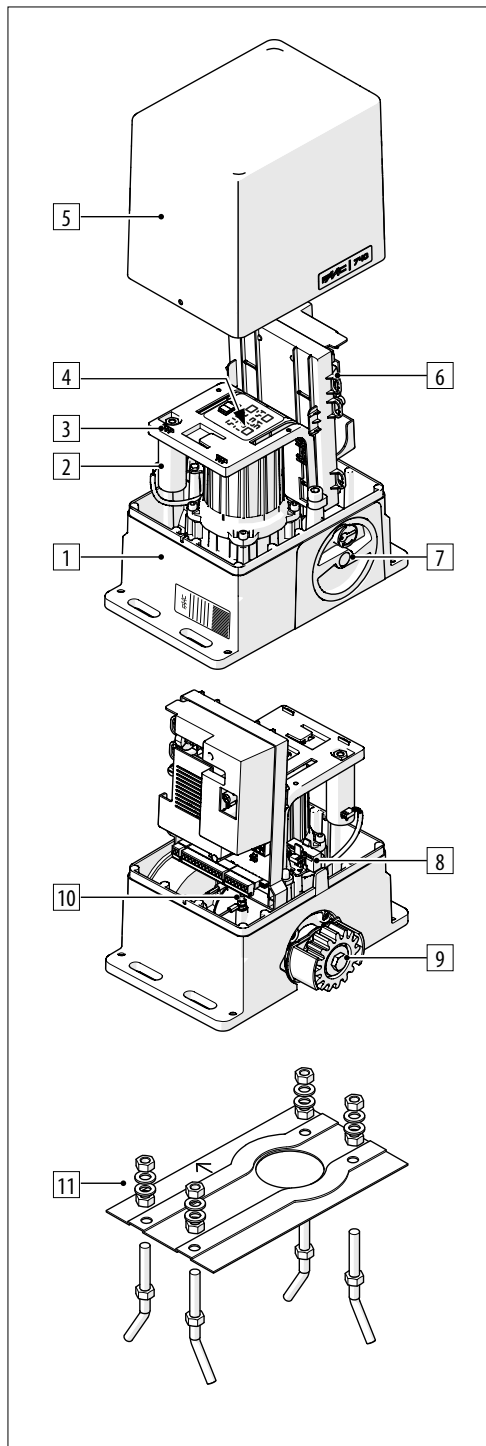

COMPONENTS SUPPLIED SEPARATELY

The installation requires the following components FAAC.

- 16 Nylon rack with screws (for leaves weighing up to 400 kg max) and self-tapping screw kit
- or
- 17 Steel rack with spacers (for leaves weighing more than 400 kg)

DANGER, AUTOMATIC MOVEMENT warning sign

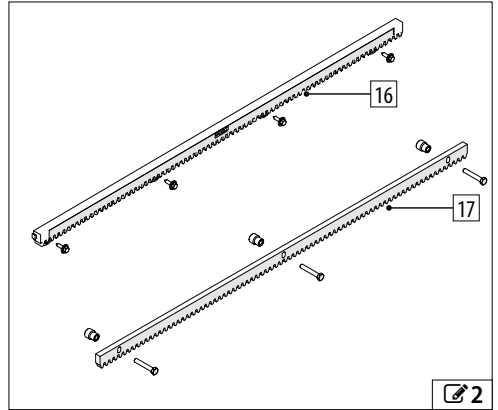

2.10 DIMENSIONS

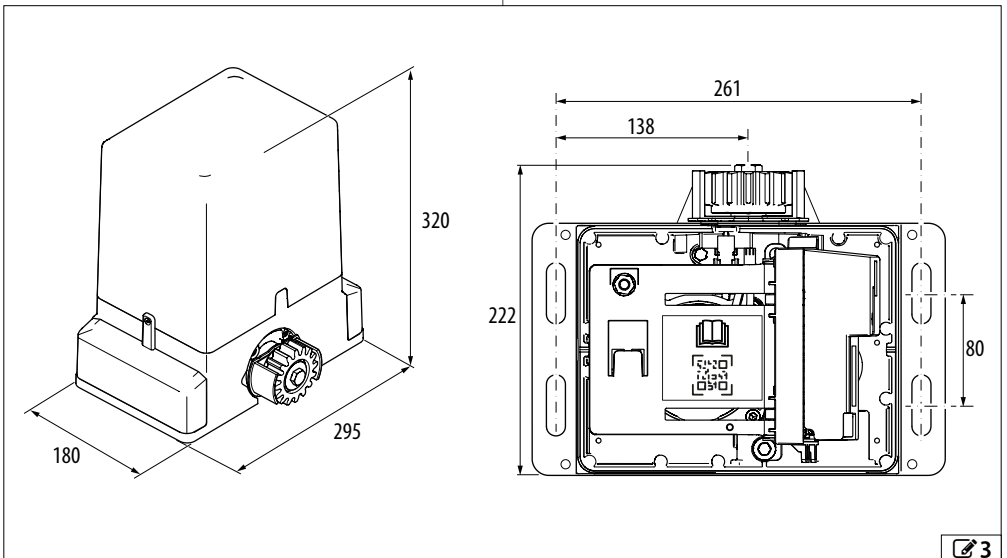

2.11 EXAMPLE SYSTEM

The example is an illustration only and is just one of the possible applications.

- | | | |
|----|---|---|
| 1 | Mains power supply | 3G 1.5 mm ² (max 2.5 mm ²) |
| 2 | Junction box | |
| 3 | Circuit breaker and differential switch | |
| 4 | Gearmotor | |
| 5 | Flashing light | |
| 6 | Photocell RX | |
| 7 | Sensitive edges | |
| 8 | Photocell TX | |
| 9 | Key button | |
| 10 | Mechanical stop | |

If an emergency stop button is fitted (in accordance with EN 60947-5-1), double insulated cables must be used.

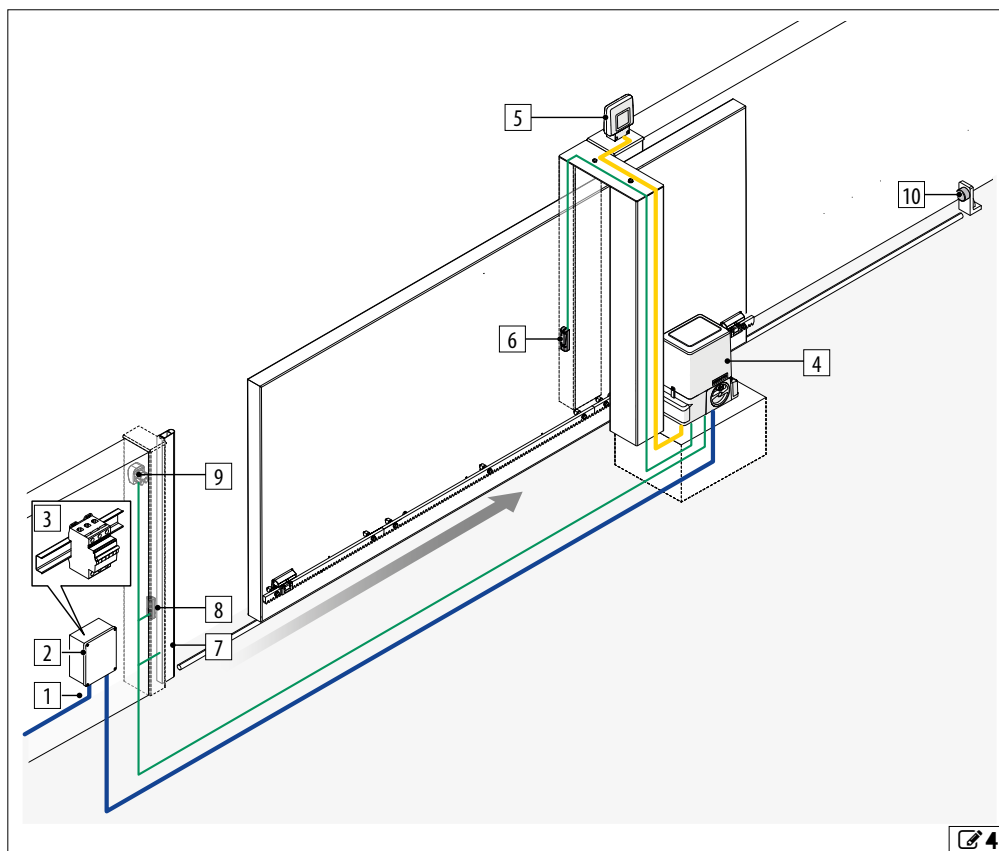

2.12 INSTALLATION DIMENSIONS

■ FOUNDATION PLATE

Opening to the left

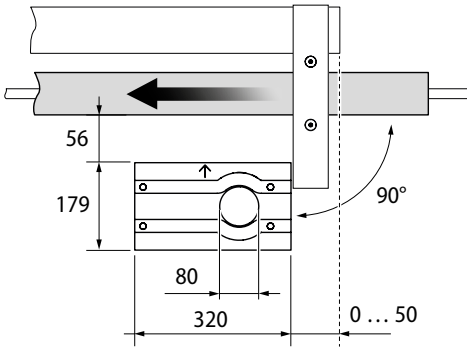

Opening to the right

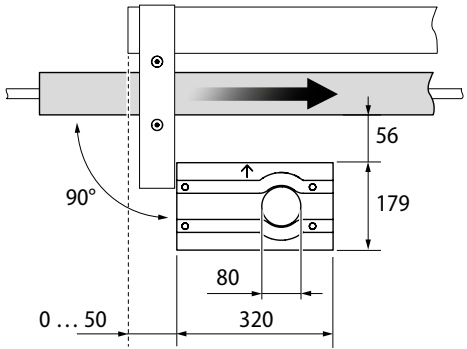

Height of the upper edge of the pinion from the ground.

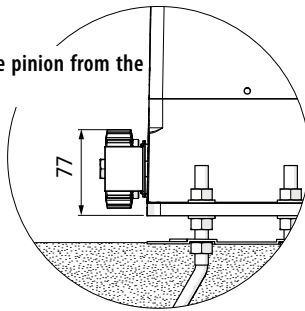

■ Steel rack

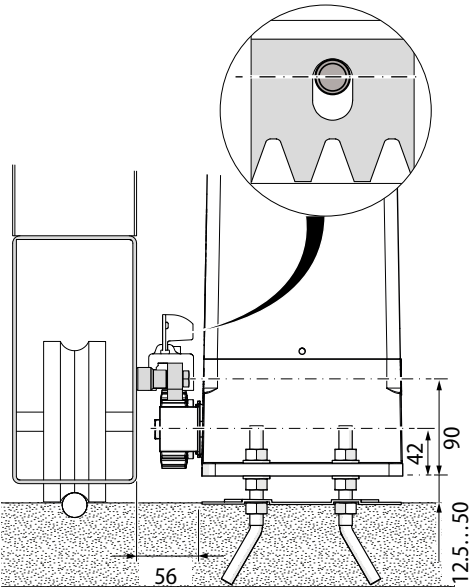



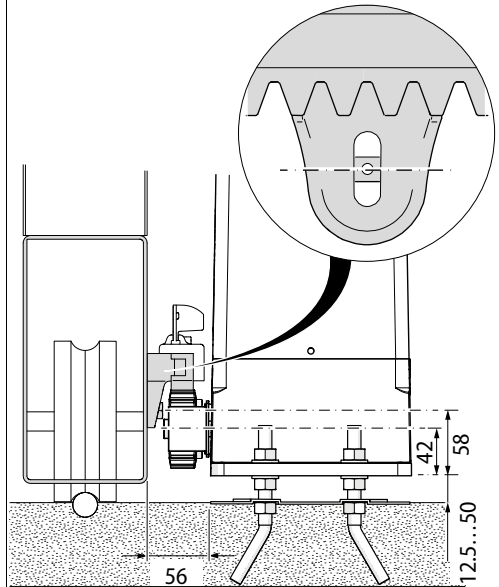







■ Nylon rack



3. MECHANICAL INSTALLATION

TOOLS REQUIRED

The tools required are indicated below.

 <p>Spanner 8, 10, 13, 19</p>	 <p>Phillips screwdrivers 1</p>
 <p>Round head Allen key 2.5</p>	 <p>Level</p>
 <p>Drill bit for metal 5, 6.5</p>	 <p>Thread cutter (for screw-on steel rack) M8</p>
 <p>Screw clamp</p>	 <p>Welder (for steel rack to be welded on)</p>
 <p>Angle grinder</p>	<p>TORQUE ADJUSTMENT - comply with fastening torque indicated in the figure. E.g.: Spanner 7 set at 2.5 Nm</p>  <p>2.5 Nm</p>

3.1 INSTALLING THE FOUNDATION PLATE

The product must be installed with the foundation plate.

i Before proceeding, the cable conduits must be laid.

1. Assemble the foundation plate.
2. Make the hole in the ground.
 - Make sure that the cable conduits protrude by approximately 15 cm, in the correct position with respect to the gearmotor and fill with concrete.
3. Place the plate at the centre of the foundation, leaving its surface uncovered.
 - Clean any concrete from the surface of the plate and the nuts with washers so that they can be subsequently adjusted.
 - Check the plate is horizontal using a spirit level.
4. Wait for the concrete to set.

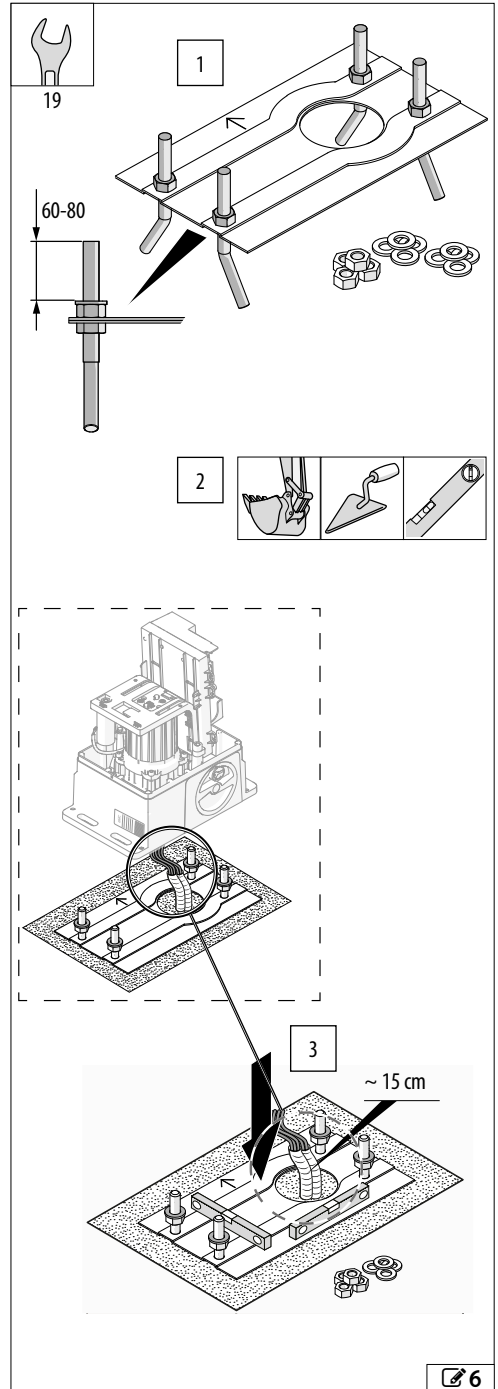

3.2 INSTALLING THE GEARMOTOR

1. Make sure that the concrete of the plinth has set completely, then adjust all the support nuts to the height indicated in figure (H).
2. Place the washers on the nuts. Position the gearmotor in correspondence with the 4 fasteners.
 - Pass the electric cables through the hole in the base so that they protrude by approximately 70 cm.

i Be careful not to damage the electrical cable tubes.

3. Make sure that the gearmotor is level. Insert the washers and nuts.
 - Do not tighten the nuts so that the height can be adjusted when the rack is being installed.

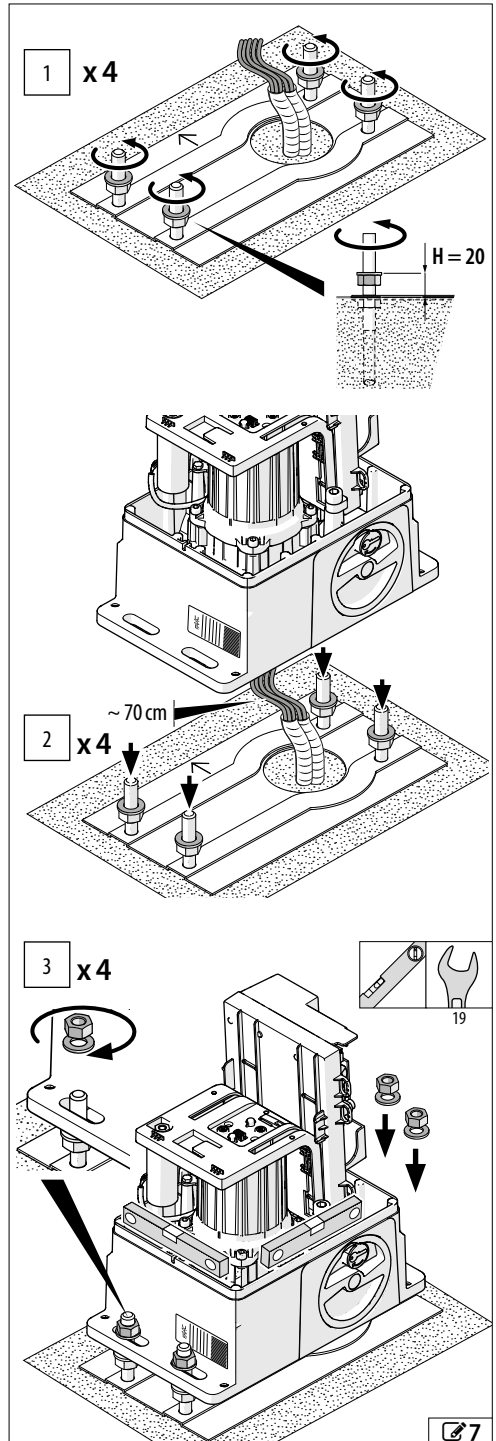

3.3 INSTALLING THE RACK

- i** - DO NOT weld the spacers onto the racks.
- DO NOT weld the elements of the rack together.
- DO NOT apply grease or other lubricants to the racks.

STEEL RACK - WELD-ON FASTENINGS

- i** **Rack thickness:** 8 mm for leaves weighing up to 400 kg max, 12 mm for leaves weighing more than 400 kg.

1. Screw 3 spacers onto each element of the rack, positioned so that they touch the top of the slots. Open the leaf manually.
2. Rest an element on the pinion. Check that it is horizontal and secure it to the leaf using a screw clamp.
3. Weld the first spacer to the leaf and then move the leaf with the rack resting on the pinion. Make sure that it is horizontal and weld on the other spacers.

- i** Protect the gearmotor from weld spatter. DO NOT connect the earth of the welder to the gearmotor.

4. Move the leaf. Connect the next element (use screw clamps and a support). Rest it on the pinion, make sure that it is horizontal, and weld the spacers. Remove the screw clamps and repeat the procedure to complete the rack.

- i** If an element of the rack has to be shortened, cut it with an angle grinder so that you leave two fastening points.

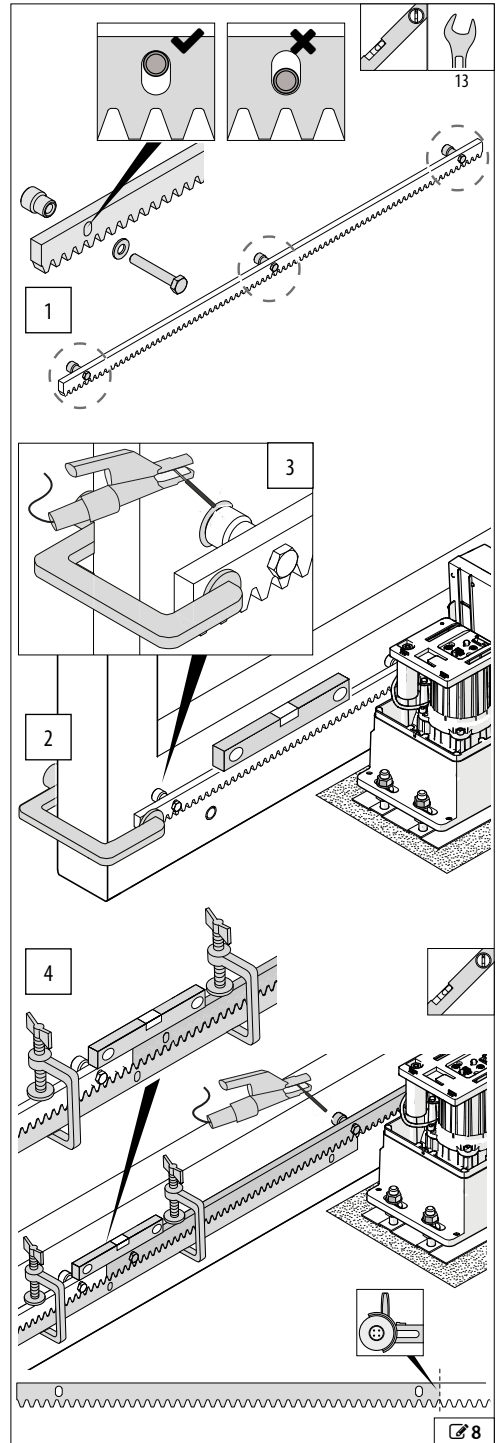

STEEL RACK - SCREW-ON FASTENINGS

i **Rack thickness:** 8 mm for leaves weighing up to 400 kg max, 12 mm for leaves weighing more than 400 kg. The rack installation accessories contain screws for aluminium or steel leaves. Use specific screws for other materials.

1. Open the leaf manually. Rest an element on the pinion. Place a spacer between the rack and the leaf so that it touches the top of the slot. Check that it is horizontal. Mark the position of the hole to be drilled on the leaf.
2. Drill the hole and make a thread in it.
3. Fasten using the screw and washer. Move the leaf with the rack resting on the pinion. Make sure that it is horizontal and fasten the other spacers.
4. Move the leaf manually. Connect the next element (use screw clamps and a support).
5. Rest it on the pinion, make sure that it is horizontal, and fasten the spacers.

Remove the screw clamps and repeat the procedure to complete the rack.

i If an element of the rack has to be shortened, cut it with an angle grinder so that you leave two fastening points.

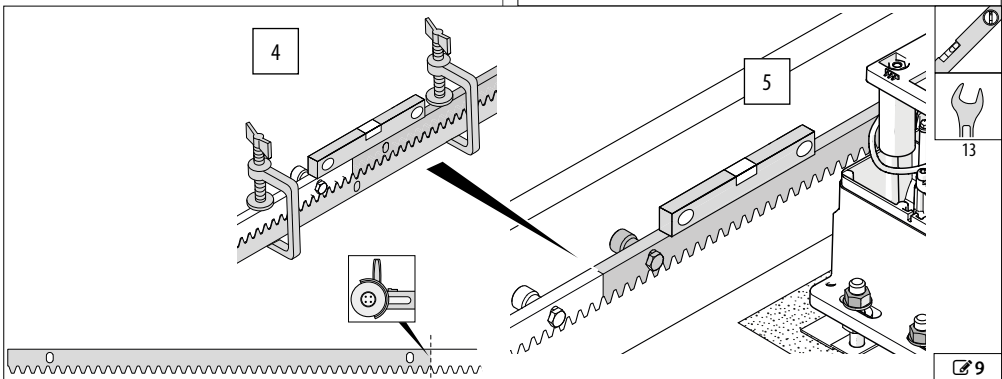
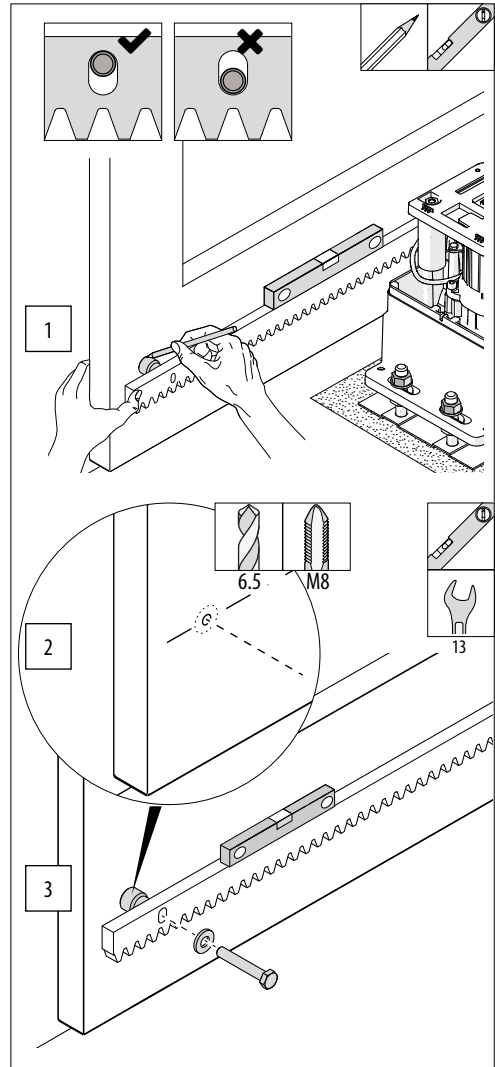

NYLON RACK

i Rack thickness: 20 mm for leaves weighing up to 400 kg max.

1. Close the leaf manually. Rest an element of the rack on the pinion. Make sure that it is horizontal using a spirit level.
2. Drill holes at the centre of the slots.
3. Fasten using suitable screws and washers.

i Self-tapping screws and washers are available for aluminium or steel and should be ordered separately.

4. Move the leaf manually. Install the next interlocking section at the end of the previous one and rest it on the pinion. Make sure that it is horizontal using a spirit level.
 5. Drill holes at the centre of the slots.
 6. Fasten using suitable screws and washers.
- Repeat the procedure to complete the rack.

i If an element has to be shortened, cut it with an angle grinder so that you leave two fastening points.

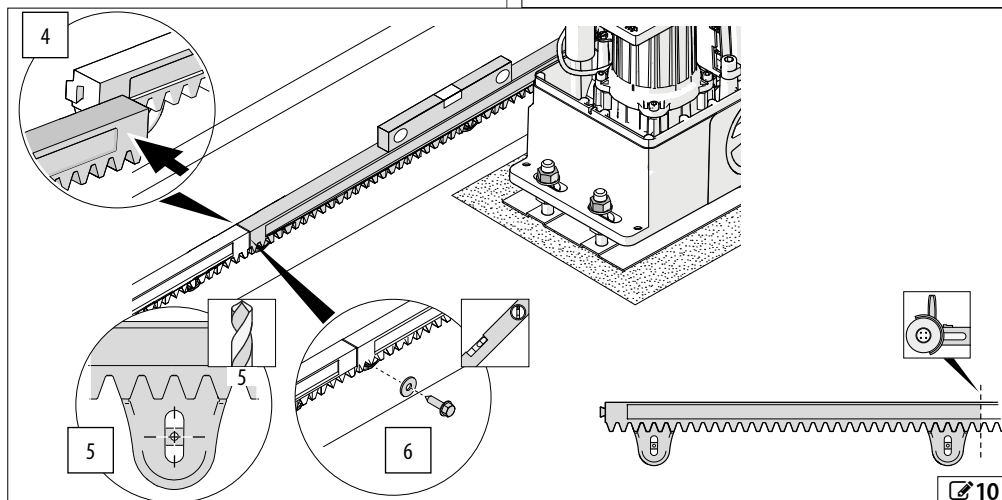
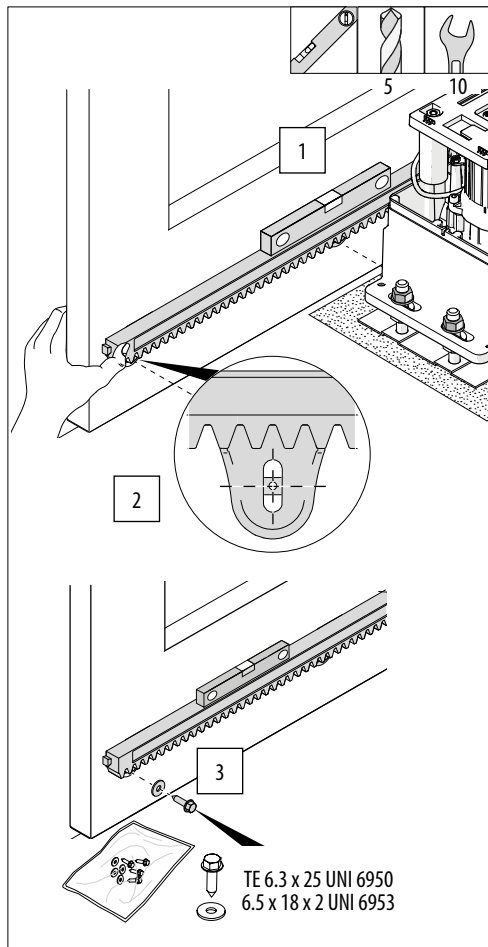

3.4 ADJUSTING AND FASTENING PERMANENTLY

indicated in the figure.

In order for it to work correctly, the rack must never rest on the pinion.

1. Lower the gearmotor: turn the 4 support nuts clockwise by half a turn (a constant distance between the pinion and rack is obtained for the entire length of travel).
2. Carry out the following checks (move the leaf manually to check the entire length of travel and all the elements of the rack).
 - Distance: when the gearmotor is locked, it must be possible to move the leaf a few millimetres to the left and right by hand.
 - Gearmotor levelling: use a spirit level.
 - Centring (A) of the rack and pinion.
3. Tighten the upper nuts to the fastening torques

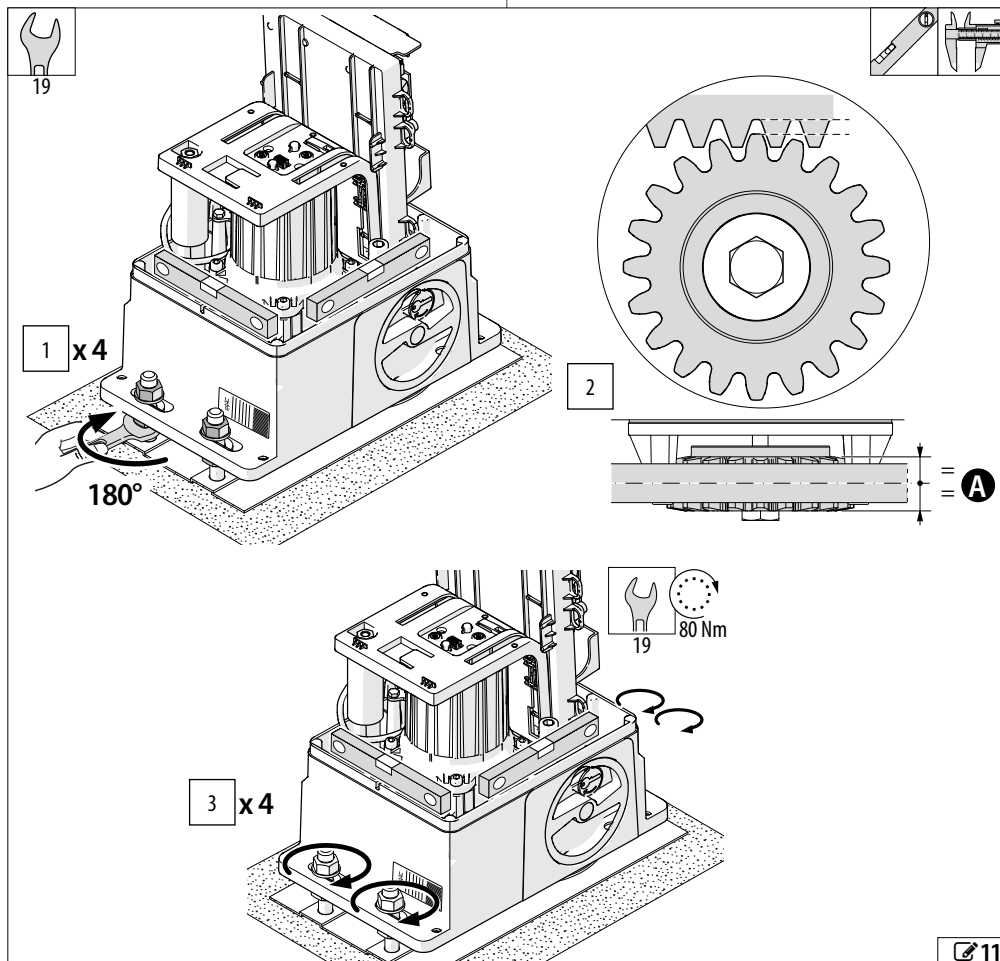

4. ELECTRONIC INSTALLATION

4.1 POSITION THE BOARD UNIT HORIZONTALLY

1. With the power supply disconnected, slide the board unit along the guide, paying attention to the cables present.
2. Place it horizontally, in contact with the guide.

4.2 CONNECTING AND STARTING THE ELECTRONIC BOARD

Refer to the § E781 S LC instructions to carry out the electronic installation and start-up of the automation:

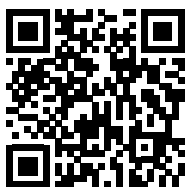

<https://www.faac.help/products/e781/>

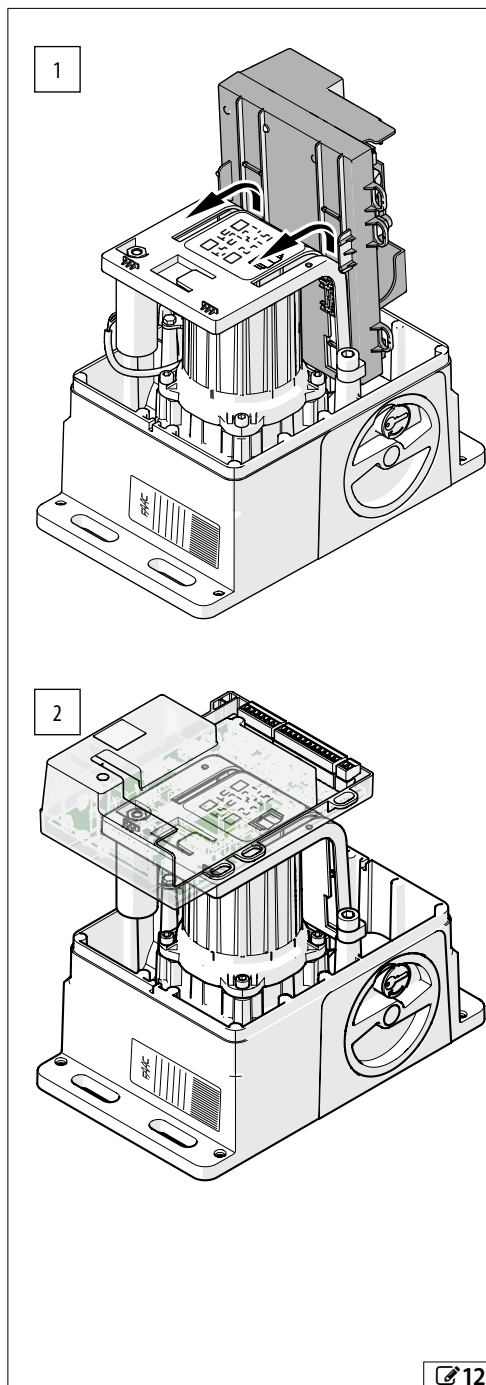

4.3 INSTALLING THE LIMIT SWITCHES

i The two limit switches are marked with different symbols: square / circle.



The limit switch marked with the **SQUARE** must **always** be positioned to the **right** of the gearmotor.
 The limit switch marked with the **CIRCLE** must **always** be positioned to the **left** of the gearmotor.

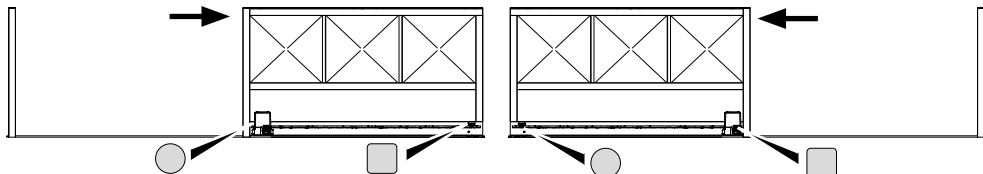

1. Assemble the limit switches. If a steel rack is installed, insert the spacer (A) and position it according to the thickness of the rack (8 or 12 mm*).

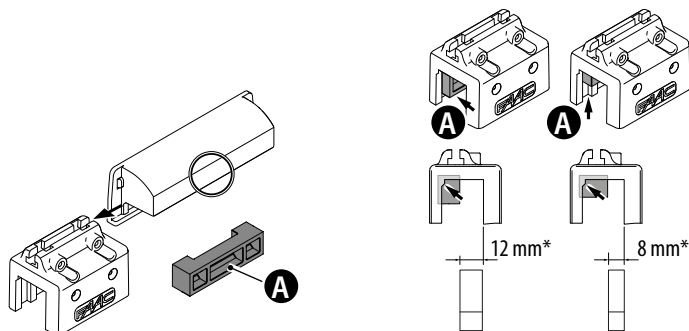

2. Release the gearmotor and open the leaf manually in order to install the OPENING limit switch. Switch on power to the electronic board and program the direction of movement (see E781 S LC programming instructions).

3. Position the **OPENING** limit switch (OP) at the end of the rack according to the opening direction. Slide the limit switch along the rack in the opening direction until the **corresponding LED on the board turns off**. Slide the limit switch along the rack for about another 4 cm.

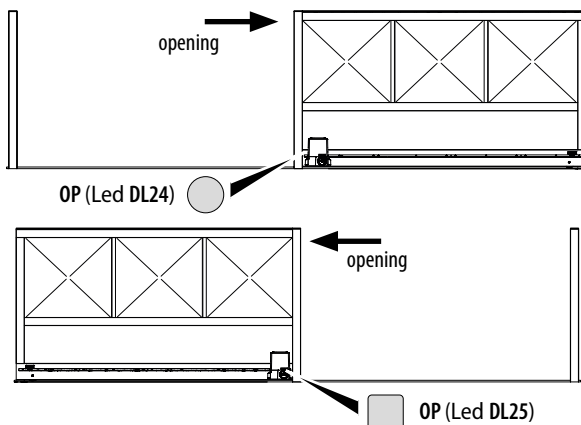

4. Follow the same procedure to install the closing limit switch: close the leaf manually and position the **CLOSING** limit switch (CL) at the end of the rack according to the closing direction of the leaf. Slide the limit switch along the rack in the closing direction until **the corresponding LED on the board turns off**. Slide the limit switch along the rack for about another 4 cm.

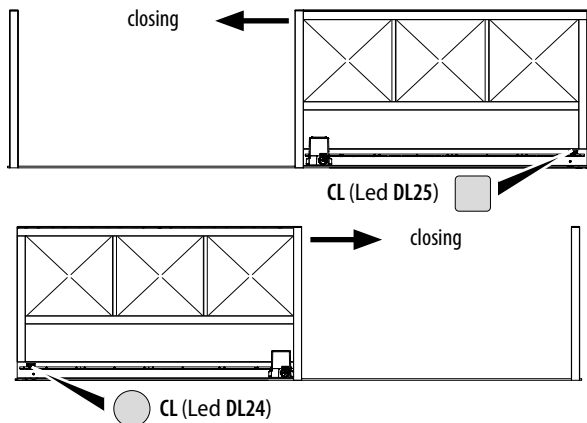

5. Fasten both limit switches using the 4 screws provided (B, then C).

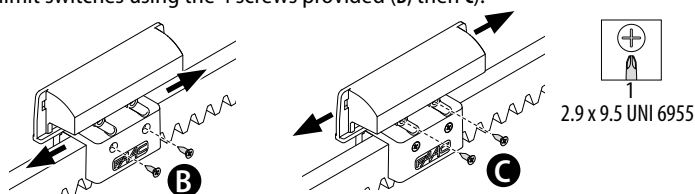

6. At the end of the procedure, restore gearmotor operation.

5. PUTTING INTO SERVICE

Once the electronic installation has been completed and the automation has been started up, carry out the final operations listed below in accordance with the electronic board instructions.



<https://www.faac.help/products/e781/>

5.1 FINAL OPERATIONS

1. Carry out a complete functional test of the automation and all the installed devices.
2. Make sure that the forces generated by the leaf are within the limits permitted by the current regulations. Use an impact force tester in accordance with standard EN 12453. For non-EU countries, if there are no specific local regulations, the static force must be less than 150 N. If necessary, adjust the anti-crushing system and make any other adjustments that may be necessary.
3. Make sure that the maximum force required to move the leaf manually is less than 225 N for residential areas and 260 N for industrial or commercial areas
4. Position the board unit vertically and then fit the cover and the bracket guards.
5. Highlight all areas with adequate warning signs in which there are still residual risks, even if all possible safety measures having been adopted.
6. Place a "DANGER, AUTOMATIC MOVEMENT" sign (not supplied) in a prominent position on the gate.
7. Attach the CE marking to the gate.
8. Fill out the EC declaration of conformity and the system register.
9. Give the EC Declaration to the owner/operator of the automation, together with the system register, the maintenance plan, the instruction manual and the "Manual operating mode" label to be affixed in a visible position by the property manager.

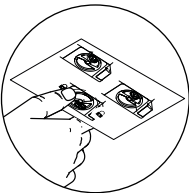

REPOSITION THE BOARD UNIT VERTICALLY

After start-up is complete, reposition the board unit so that it is vertical.

1. With the power supply disconnected, slide the board unit along the guide, paying attention to the cables present.

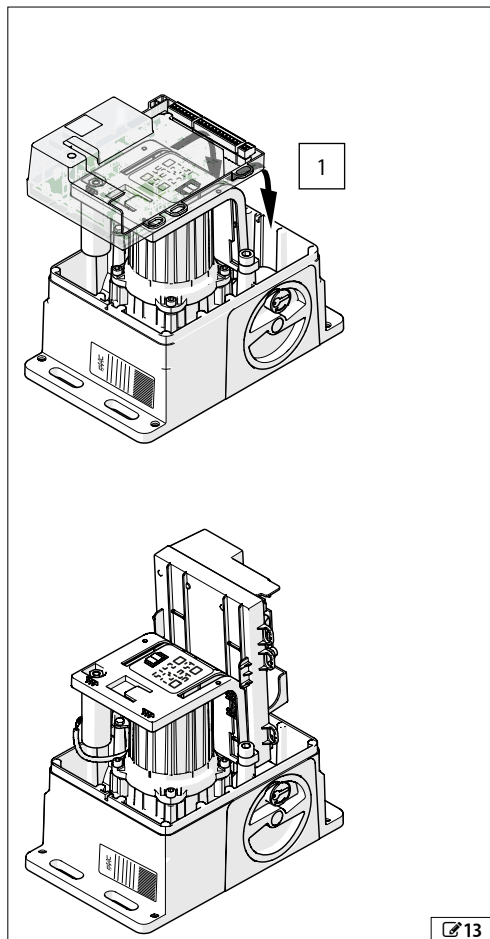

REPLACE THE COVER AND THE GUARDS

2. Replace the cover.
3. Position the guards and secure the parts. Apply the adhesive sign to the cover: risk of fingers and hands being trapped due to the rotation of the pinion and the movement of the rack.

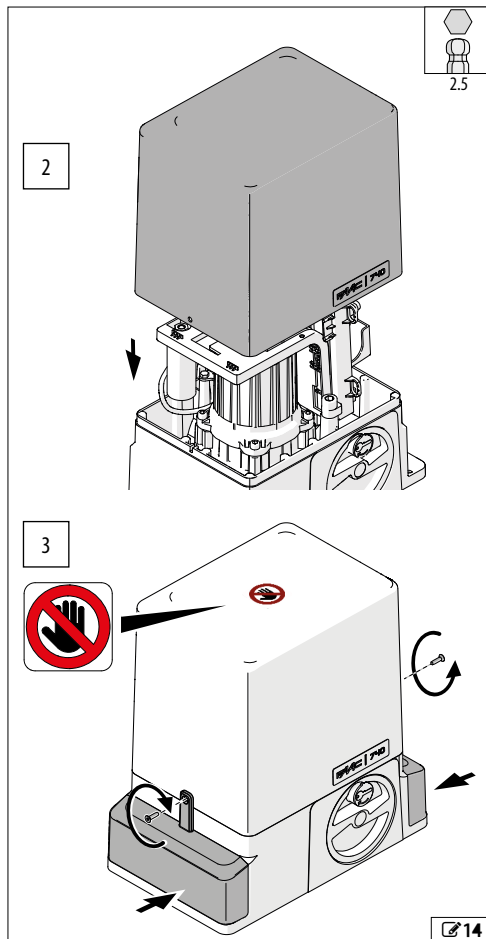

6. MAINTENANCE

6.1 SCHEDULED MAINTENANCE

It is mandatory to carry out the operations indicated in table  Maintenance of 740 C - 741 C, in order to keep the operator working reliably and safely.

The installer/machine manufacturer is responsible for drawing up the maintenance plan for the machine, supplementing this list or shortening maintenance intervals according to the machine characteristics and current local regulations.

3 Scheduled maintenance

Maintenance 740 C - 741 C	Frequency in months
Check that the cover and all the movable guards are integral and properly secured. Tighten screws and bolts where necessary.	12
Check that the body of the operator is undamaged.	12
Check the fastening torque of the brackets and screws that secure the gearmotor to the foundation plate.	12
Check the wear of the pinion (replace if necessary).	12
Check that the pinion and rack engage correctly and that the distance between them is correct.	12
Check that it is irreversible.	12
Check that the limit switches are intact and their correct operation and adjustment.	12
Check that the cable glands are intact and that they are functional.	12
Make sure that the manual release is working correctly.	12
Check that the hand-hazard warning sticker is present and intact.	12
Generally clean the outside of the gearmotor with a clean cloth, dampened with a neutral detergent.	12
Check that the connectors and wiring are intact. Check that there are no signs of overheating, burning etc. of electronic components.	12
Check that the earth connections are intact and that the circuit breaker and differential switch are working correctly.	12
Check that the encoder is working properly.	6

Maintenance of other components: STRUCTURES	Frequency in months: follow the manufacturer's instructions
Check the plinth, the structures and components of the building/fence adjacent to the automation, ensuring there is no damage, cracking or subsidence.	
Check the gate's area of movement, ensuring it is free from obstacles, objects or deposits which would reduce the effectiveness of the safety measures.	
Check that there are no gaps in the perimeter fence and that any protective grilles in the area where it overlaps with the mobile leaf are intact.	
Ensure that there are no sharp protrusions which could represent a perforation or hooking hazard.	
Check the leaf containing guide and the anti-tipping column, ensuring they are correctly fastened and intact.	
Perform a general clean of the area of movement of the gate.	
Check that the sliding guides are straight and not excessively worn.	
Check that the mechanical stops are fastened solidly and in good condition. This check must be performed on both sides, simulating any knocks which could occur during use.	

Maintenance of other components: GATE	Frequency in months: if not indicated, follow the manufacturer's instructions
Check the frame: make sure that it is fixed correctly, that it is intact and that there is no deformation or damage. Tighten screws and bolts where necessary.	-
Check the leaf: make sure that it is intact and that there is no deformation or damage.	-

Maintenance of other components: GATE	Frequency in months:
	if not indicated, follow the manufacturer's instructions
Check that the pedestrian door integrated in the sliding leaf is intact (if present).	-
Check that the bearings are in good condition and there is no friction. Check the wheels, ensuring that they are intact, correctly fastened and free of deformation, wear and rust.	-
Check the rack, ensure it is straight, not worn, that it is the correct distance from the pinion along its entire length and correctly fastened to the gate.	12
Cantilever gate, check the solidity of the guide system for the suspended leaf and the counterweight, if present.	
Perform a general clean of the area of movement of the gate.	12
Make sure that the pictograms are present and intact. If they are missing or damaged, replace them.	12
PROTECTIVE DEVICES AND CONTROL DEVICES	
Check that the protective devices are intact and that they operate correctly.	-
Check that the control devices are intact and that they operate correctly.	-
Check that each pair of photocells is working correctly and that there is no optical/light interference between the pairs of photocells.	6
Check that indicator lights are intact that they are working correctly, if present.	-
GATE COMPLETE WITH GEAR MOTOR	
Check that the gate operates properly in both directions with all the devices installed.	6
Check that the gate moves correctly - smooth, regular and without making abnormal noises.	6
Check that both the opening and closing speed are correct and that the expected stop positions and slowdowns are correct.	6
Check that the safety devices (e.g. sensitive edges) are working correctly, if present.	6
Repeat the operations in the § Final checks section.	6
Check that the gate's CE marking and the DANGER, AUTOMATIC MOVEMENT warning sign is present, intact and legible.	12

7. INSTRUCTIONS FOR USE

It is the installer's responsibility to provide the operator of the automation system with the instructions for use, maintenance and disposal, incorporating the following information and the instructions for the electronic board E781 S LC.

7.1 EMERGENCY USE

In emergencies or if there is a fault, turn off the power supply to the automation. If the leaf can be moved safely by hand, use the **MANUAL OPERATION** mode; otherwise place the automation out of service until it has been reset/repared.

In the case of a breakdown, the automation must be reset/repared exclusively by the installer/maintenance technician.

7.2 MANUAL OPERATION

In order to move the leaf manually, the gearmotor has to be released using the knob with key.

RELEASING THE GEARMOTOR

1. Rotate the lock cover.
2. Insert the key and turn it clockwise by 90°.
3. Turn the release knob clockwise until it stops.

 During manual operation, gently guide the leaf the whole way. Do not push it and let it slide freely. Do not leave the gearmotor in the released mode: restore automatic operation after moving it manually.

RESTORING OPERATION

 Make sure that the gate is closed with the relative limit switch engaged before turning the power back on and operating the automation.

4. Turn the release knob anticlockwise until it stops.

 Move the leaf manually to make sure that the mechanical system meshes correctly.

When finished, remove the key and reposition the lock cover.

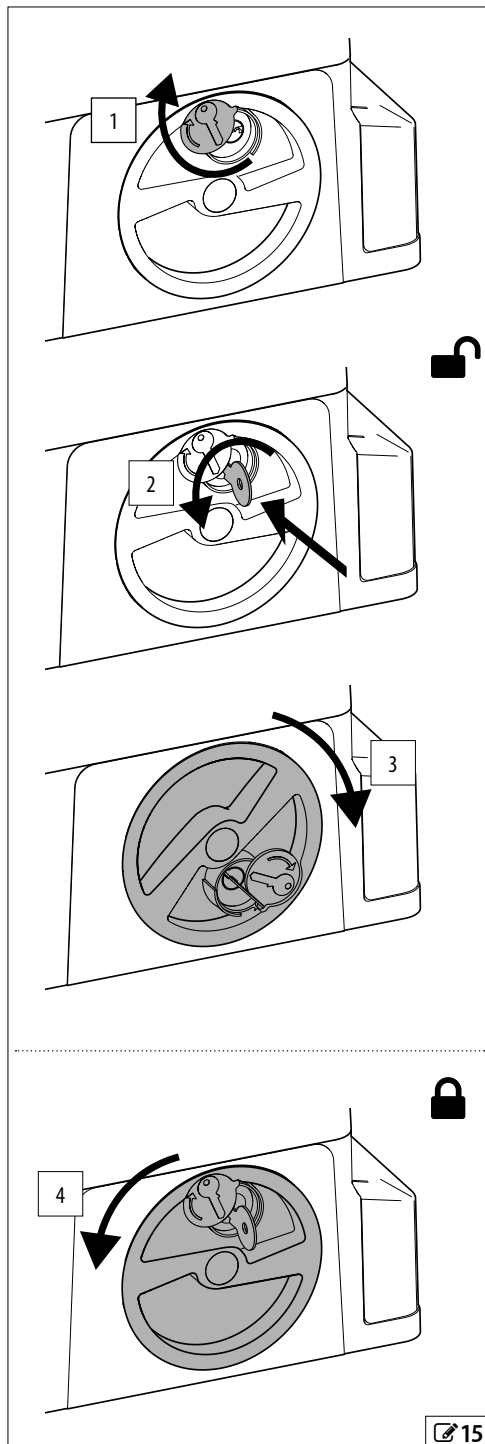

1 Foundation for leaves of maximum weight and width

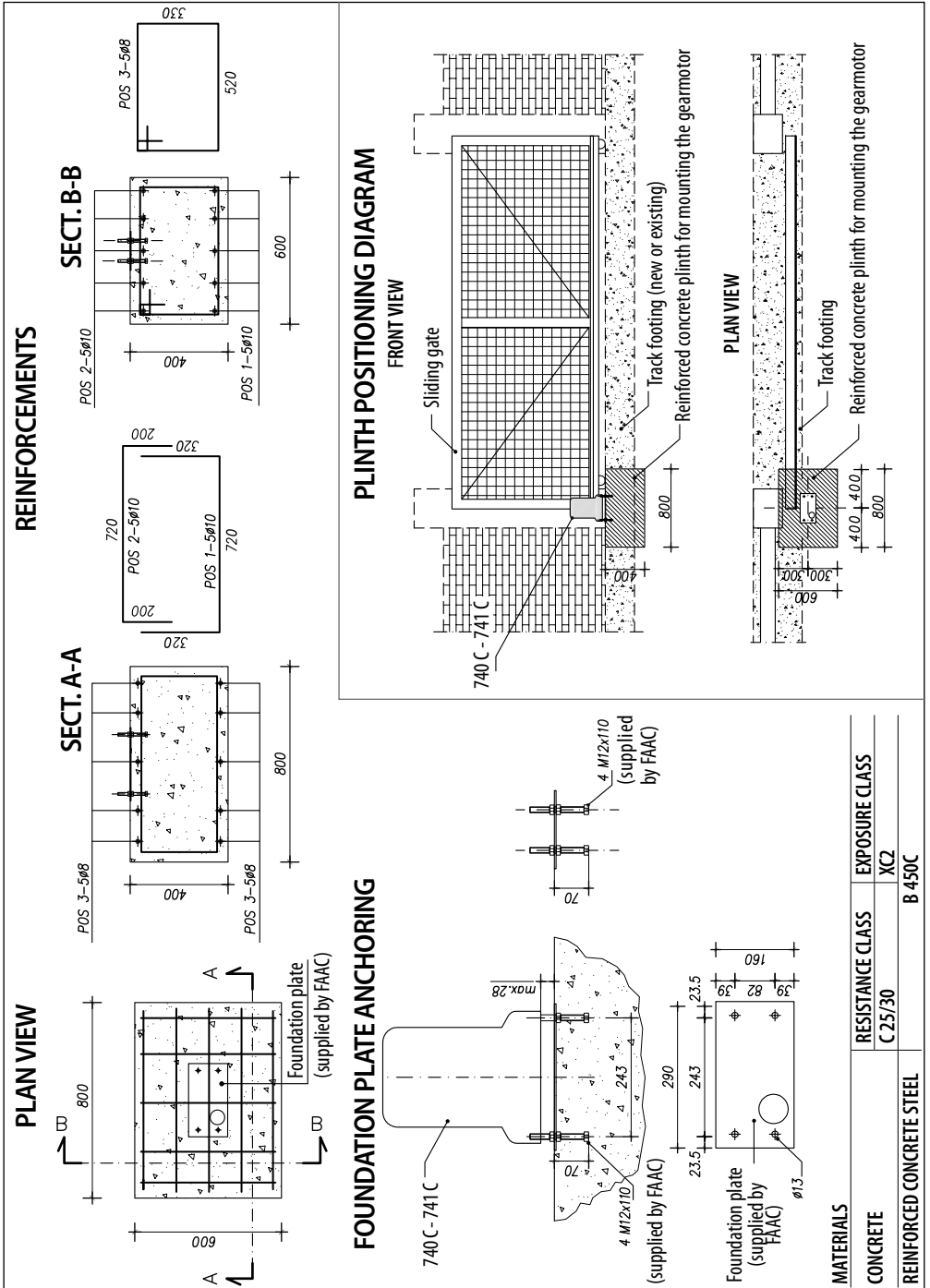

A BRAND OF
FAAC TECHNOLOGIES

FAAC S.p.A. Soc. Unipersonale
Via Calari, 10 - 40069 Zola Predosa BOLOGNA - ITALY
Tel. +39 051 61724
www.faac.it - www.faac technologies.com



Points de collecte sur www.quefairendesdechets.fr
Privilégiez la réparation ou le don de votre appareil !