

# AIR2-Aria/W



WIRELESS KEYPAD WITH LCD GRAPHIC DISPLAY



The Aria/W wireless keypad provides all the necessary functions for control and management of a Inim installation equipped with an Air2 system, which it can interface with through the Air2-BS200 transceiver. It integrates all the functions present on hardwired keypads and provides a graphic display with user-friendly icons and 4 easy-to-use function keys.

The keypad Aria/W is equipped with a wall bracket and a table bracket. It is equipped with an accelerometer which provides both anti-tamper and "wakeup" from stand-by functions, whereas the brightness sensor controls the display and key brightness optimally with respect to the surrounding environment.

Moreover, it has an automatic shutdown function in the event of loss of wireless connection.

Aria/W is also equipped with a connector which allows hardwiring connection if required.

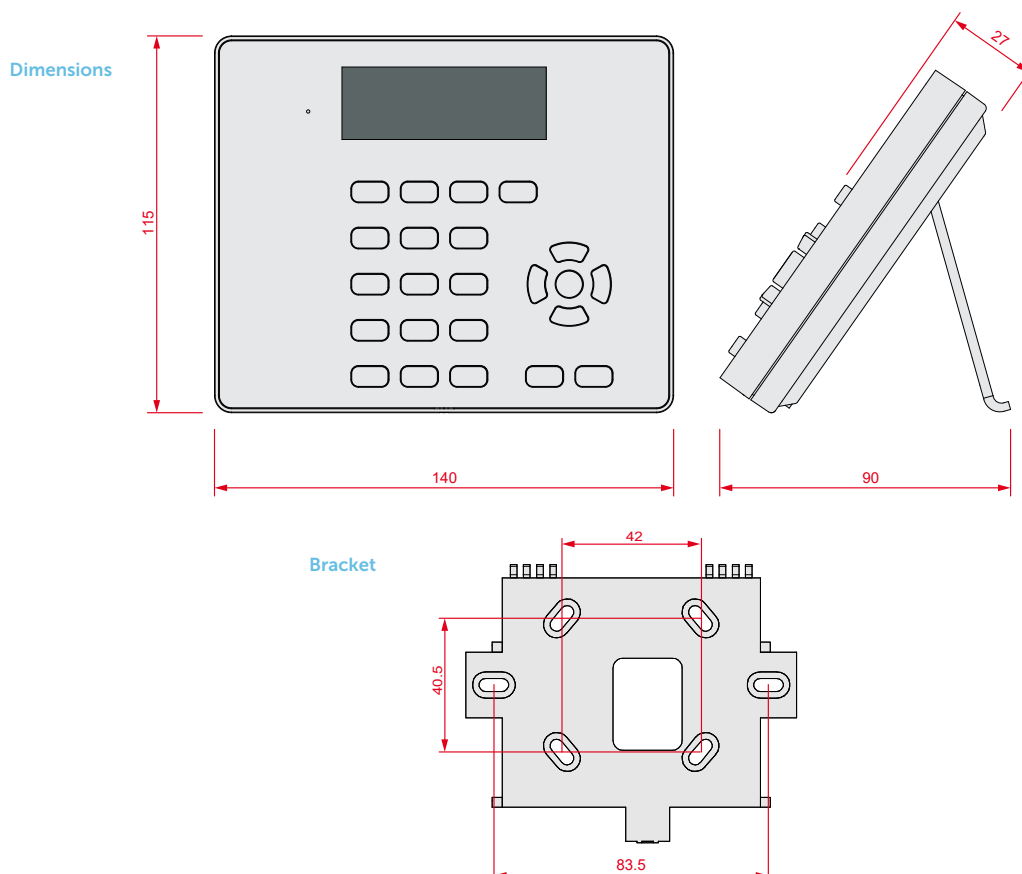



## Main features

Communication with Air2-BS200 transceiver	Two-way
Operating frequency	868 MHz
Programmable supervision time of wireless devices	from 12 to 250 minutes
Number of Aria/W keypads supported by Air2-BS200	Maximum 4
Backlit graphic display	Yes
Icon Easy4U interface	Yes
Programmable backlight in operation	Yes
Anti-glare sensor	Yes
4 signal LEDs	Yes
Signal buzzer	Yes
Protection	Inertial tamper protection
Accelerometer controlled "Wakeup" function	Yes
Wireless channel quality analysis	Yes
Mounts to "503" box	Yes
Table bracket	Yes
Optional 6-20 Vdc power-supply connector	Yes
Battery	CR17450 Lithium battery - 3V - 2200mAh, x2
Estimated battery life	2 years
Dimensions (HxWxD)	140x115x27 mm
Weight	255 g
Security grade	2
Environmental class	II

## ORDER CODES

**Air2-Aria/WB:** wireless keypad with graphic backlit display, in white.